



CITY OF COEUR D'ALENE Manufactured Home Setting Permit Application

Job Address N S E W _____ ST AVE DR RD PL LN CIR CT WY LP

Legal Description LOT _____ BLOCK _____ SUBDIVISION _____ OR SERIAL # _____ Value of Work _____

Type of Work: Mfg Home New Setting Mfg Home Reset Designated Manufactured Home Setting: Standard Permanent Set Mobile to Real Property

Manufacturer _____ Year _____ Designed Roof Snow Load _____

Total Square Footage: _____ Height: _____ Sections: Single Double Triple

Is the home currently within City Limits of Coeur d'Alene? Yes No

Please provide the location it is being moved from (address/city/state/zip): _____

Owner: _____ Contact Person _____ Phone _____ Fax _____

Address(C/S/Z): _____ E-mail _____

Manufacturer Home Installer: _____ Contact Person _____ Phone _____ Fax _____

Address (C/S/Z): _____ E-mail _____

State Manufacturer Installer License Number _____ Expiration date (M/D/Year) _____

I understand that separate electrical, plumbing, and mechanical permits may be required. I understand no setting or work is to be done until a valid permit has been issued by the Building Services Department. The owner/authorized agent is responsible for verification of all setbacks on the site plan. New installations shall be per manufacturer's specifications. Reset installations shall comply with the 2018 Idaho Manufactured Home Installation Standards. Building permits are required for the construction of decks (30 inches or more above finished grade), steps (four risers or more), stairways, awnings or accessory buildings. A Certificate of Occupancy is required prior to occupancy of the dwelling.

Owner/Authorized Agent _____ Date _____

Staff to complete:

Submittal Date: _____ Plan Review Fee: _____ Accepted By: _____



CITY OF COEUR D'ALENE Mechanical Permit Application

Use of building: Commercial Residential

Job Address: _____

Owner: _____

Address: _____

City/Zip: _____

Phone: _____

Fax: _____ E-Mail _____

Mech Contractor: _____

Address: _____

City/Zip: _____

Phone: _____ Lic. # _____ Exp Date _____

Fax: _____ E-Mail _____

Describe work:	<input type="checkbox"/> NONE/NO MECHANICAL WORK

- | |
|--------------------------------------------------------------------------------------------------------|
| Mechanical Requirements: |
| • ACCA Manuals J and D worksheets |
| • Plan showing locations, sizes & specific fittings of system |
| • Manufacturer's data sheets for proposed HVAC appliances |
| • Tutorial available at http://www.acca.org/speedsheet |
| • Software available for purchase at http://www.acca.org/store |
| • ResCheck/ComCheck see www.energycodes.gov/ |

Description of Item	# of items	Fee	Totals
Processing Fee	1	\$ 40	\$ 40
Air Handler < 10,000 CFM		x 14	
Air Handler > 10,000 CFM		x 22	
Ductwork (any)		x 10	
Boiler/Refrig 1-100M BTU		x 18	
Boiler/Refrig 100-500M BTU		x 30	
Boiler/Refrig 501-1000M BTU		x 42	
Boiler/Refrig 1,001-1750M BTU		x 60	
Boiler/Refrig > 1750M BTU		x 100	
Clothes Dryer		x 18	
Electric Furnace		x 18	
Evaporative Coolers		x 14	
Gas Equipment < 100,000 BTU (Gas furnace, Generator)		x 18	
Gas Equipment > 100,000 BTU		x 22	
Gas Log		x 18	
Gas Piping (each outlet)		x 4	
Heat Pump & A/C 0-3 tons		x 18	
Heat Pump & A/C 4-15 tons		x 32	
Heat Pump & A/C 16-30 tons		x 42	
Heat Pump & A/C 31-50 tons		x 60	
Heat Pump & A/C > 50 tons		x 100	
Mini-Split (# of heads)		x 8	
Miscellaneous (not covered elsewhere)		x 28	
Manufactured Home Gas Hook-up		x 18	
Range (Gas)		x 18	
Type I Hood (per foot)		x 10	
Type II Hood (Typical Residential)		x 14	
VAV Units/Duct Heater		x 10	
Ventilating Fans		x 10	
Gas Insert		x 22	
Fireplace Insert		x 22	
Woodstove		x 22	
Gas Water Heater			
Specialty Plumbing Contractor Lic. #: _____		x 18	
Plan Review Fee (internal use only)			

Signature _____ Date _____

TOTAL PERMIT FEE \$ _____

Class of Work <input type="radio"/> New <input type="radio"/> Addition <input type="radio"/> Alteration <input type="radio"/> Repair <input type="radio"/> Other		
JOB ADDRESS:		
Building Owner	Phone	
Address		
City	State	Zip Code
Plumbing Contractor	Phone	
Address	Idaho License # and Exp. Date	
City	State	Zip Code
Describe Work		
Backwater Valve Existing <input type="checkbox"/> Yes <input type="checkbox"/> No		
Backflow Protection	Number of Each	Size
• Reduced Pressure Backflow Assembly	_____	_____
• Double Check Valve Assembly	_____	_____
• Other	_____	_____
NOTICE		
This permit becomes null and void if authorized work or construction authorized is not commenced within 180 days, or if construction is suspended or abandoned for a period of 180 days at any time after work has commenced.		
I hereby certify that I have read and examined this application and know the same to be true and correct. All provisions of laws and ordinances governing this type of work will be complied with whether specified herein or not. The granting of a permit does not presume to give authority to violate or cancel the provisions of any other state or local law regulating construction or the performance of construction.		
It is the duty of the person doing the work authorized by a permit to notify the Building Department that work is ready for inspection. Please call our inspection line 24 hours in advance of the requested inspection at 208-769-2391. For questions or additional information call 208-769-2267.		
I understand that it is my responsibility to contact DEQ to ascertain their requirements related to the water, sewer and storm water systems included in this permit.		
Signature _____	Date _____	

RESIDENTIAL FEE SCHEDULE	QTY X\$10	TOTAL
Bar Sinks		
Bath Tub, including shower		
Backflow Assembly (Building)		
Backflow Assembly (Landscape)		
Backwater Valve		
Clothes Washer		
Floor Drains/Hub Drains		
Gas Piping		
Kitchen Sinks and/or dishwasher		
Lavatory (wash basins)		
Mobile Home W/S Hook up		
Other		
Sewer Ejector/Sump Pump		
Sewer Service		
Showers		
Utility Sinks		
Water Closet (toilet)		
Water Heater		
Water Heater Venting (gas)		
Water Service		
Water Softener		
COMMERCIAL FEE SCHEDULE:		
Contract Price =	\$	
OFFICE USE ONLY		
3% of contract price up to and including the 1 st \$20,000		
2% of contract price in excess of \$20,000 through \$100,000		
1% of contract price in excess of \$100,000		
½% of contract price in excess of \$200,000		
PLAN REVIEW FEE		
PROCESSING FEE		\$40.00
TOTAL	(MINIMUM FEE \$50.00)	



CITY OF COEUR D'ALENE Manufactured Home Setting Permit Submittal Minimums

- 1. Completed Building and Mechanical applications, indicate if it is a single, double, or triple wide. Provide the description and value of work.
- 2. Provide the Manufactured Home Installer's State of Idaho license number and expiration date or if applicable, complete the registration exemption form.
- 3. One set of plans drawn to 1/4" scale, submitted in pdf format electronically.
- 4. If this is a reset, a floor plan of the dwelling showing all smoke detector locations.
- 5. If being set in a manufactured home park, provide the name of the park _____
- 6. If being set on a private lot provide the zoning
*If being set on a private lot that is zoned other than MH-8, you must check with the Planning Department for additional requirements as well as Water and Wastewater for additional fees.
- 7. Show all porch and deck dimensions and heights.
- 8. Provide an accurate site plan with dimensions to all property lines and/or accessory structures. Indicate the utility box location on the site plan.
- 9. The skirting must be left open in areas of the perimeter to assist the inspector with the required inspections.
- 10. Provide verification the roof is designed for a 40 pound roof snow load.
- 11. A separate water and sewer permit is required for the mobile home hook-up. This work can be performed by the installer if they have a specialty plumbing license with the State of Idaho or by a City licensed drain layer. It can also be issued to the homeowner if they are performing their own work.
- 12. If there is gas work involved, you must have a State of Idaho licensed mechanical contractor.
- 13. A separate electrical permit is required to be issued to your State of Idaho licensed contractor. It can be issued to the homeowner if they are performing their own work. These are issued by the State of Idaho Department of Building Safety, Electrical Bureau.
- 14. If this is mobile to real property you must submit a foundation plan with cross sections of footings, pads, walls, reinforcement, anchor bolts and sill plates-refer to the 2018 Idaho Manufactured Home Installation Standard for details.
- 15. **Mobile to Real Property:** Additional requirements may apply. You must contact the Kootenai County Assessor's Office for the proper form. This form is required to be on-site and provided to the building inspector at the time of inspection.
- 16. If engineering is required, it shall be designed by an engineer licensed in the State of Idaho.

Completed By

Date

SAMPLE SITE PLAN

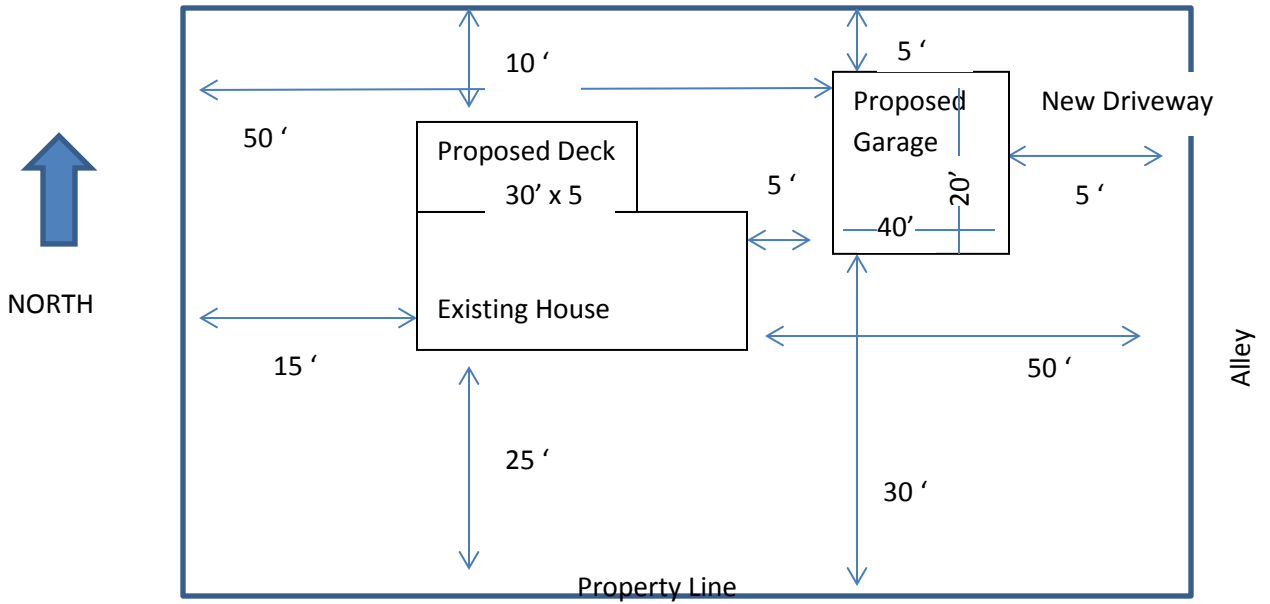

SAMPLE FLOOR PLAN

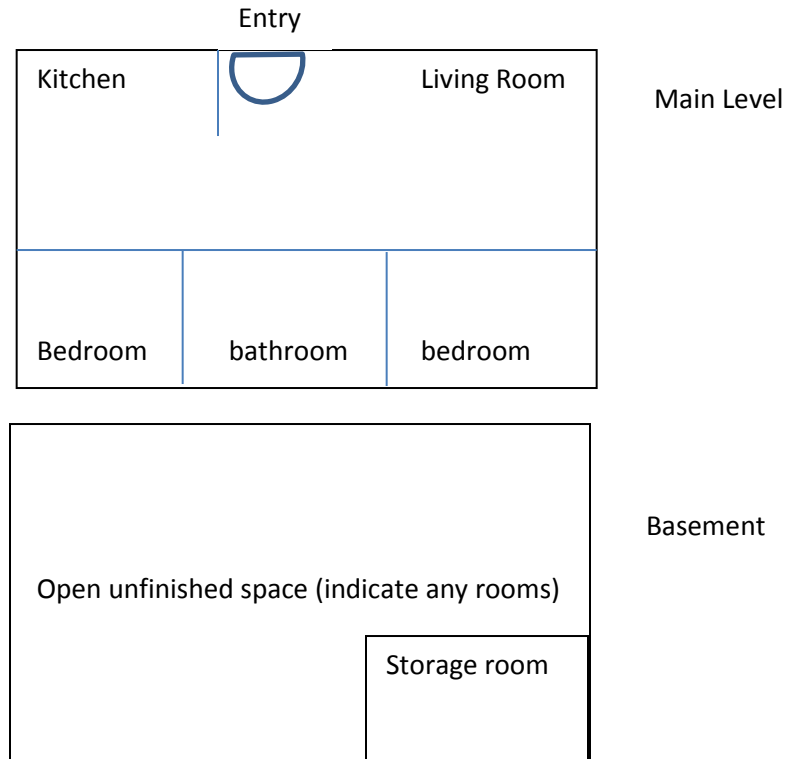



BUILDING PERMIT ADDENDUM – CONTRACTOR REGISTRATION EXEMPTION DECLARATION

Effective immediately the City of Coeur d'Alene **will not accept a building permit application** unless the applicant provides proof of contractor registration as required by Idaho Code 54-5209 or is exempt from the registration requirement.

This requirement can be satisfied in one of the following ways:

- Enter your current Idaho Contractor's Registration number and expiration date on the face of the application and attach a copy of your registration card or other documentation from the Contractor Board establishing that you are currently registered.
- Complete the following addendum by indicating that you are exempt from the registration as provided by Idaho Code 54- 5205. **In order to complete the addendum you must identify the basis for your exempt status including a reference to the Idaho Code subsection creating the exemption.**

I certify, under penalty of perjury, that I am exempt from the contractor registration requirement of I.C. 54-5209. I am exempt because _____, which is established as an exemption by I. C. 54-5205 _____.

I understand that acting in the capacity of a contractor within the meaning of Idaho Code Chapter 54 Title 52 without a current registration with the Idaho Bureau of Occupation Licenses or without being exempt as defined by Idaho Code 54-5205, is a misdemeanor punishable by a fine not to exceed one thousand dollars (\$1,000) or by imprisonment in the county jail for a term not to exceed six months, or both.

Name: (Please Print) _____

Signature: _____ Date: _____

Manufactured Housing (Residential) Landing and Stair Requirements

A minimum 3 ft x 3 ft landing is required at both exits.

Anything larger than a 4 ft x 5 ft landing requires a separate building permit.

Typical Landing, Stairs, and Railing

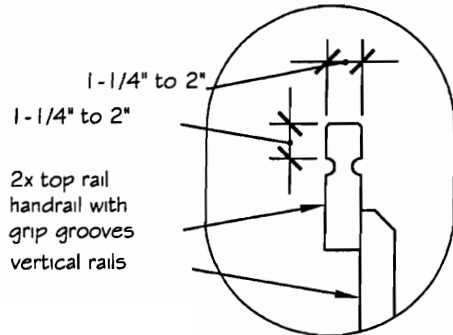

(A) Stair handrail

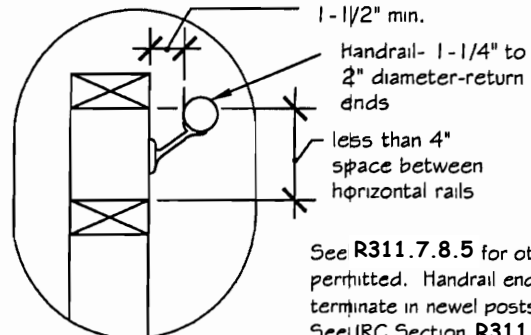

(B) Stair handrail

See R311.7.8.5 for other handrail shapes permitted. Handrail ends shall be returned or terminate in newel posts or safety terminals. See IRC Section R311.7.8.5

- minimum 3'x3' landing at all exterior doors
- min. 36" wide stairway

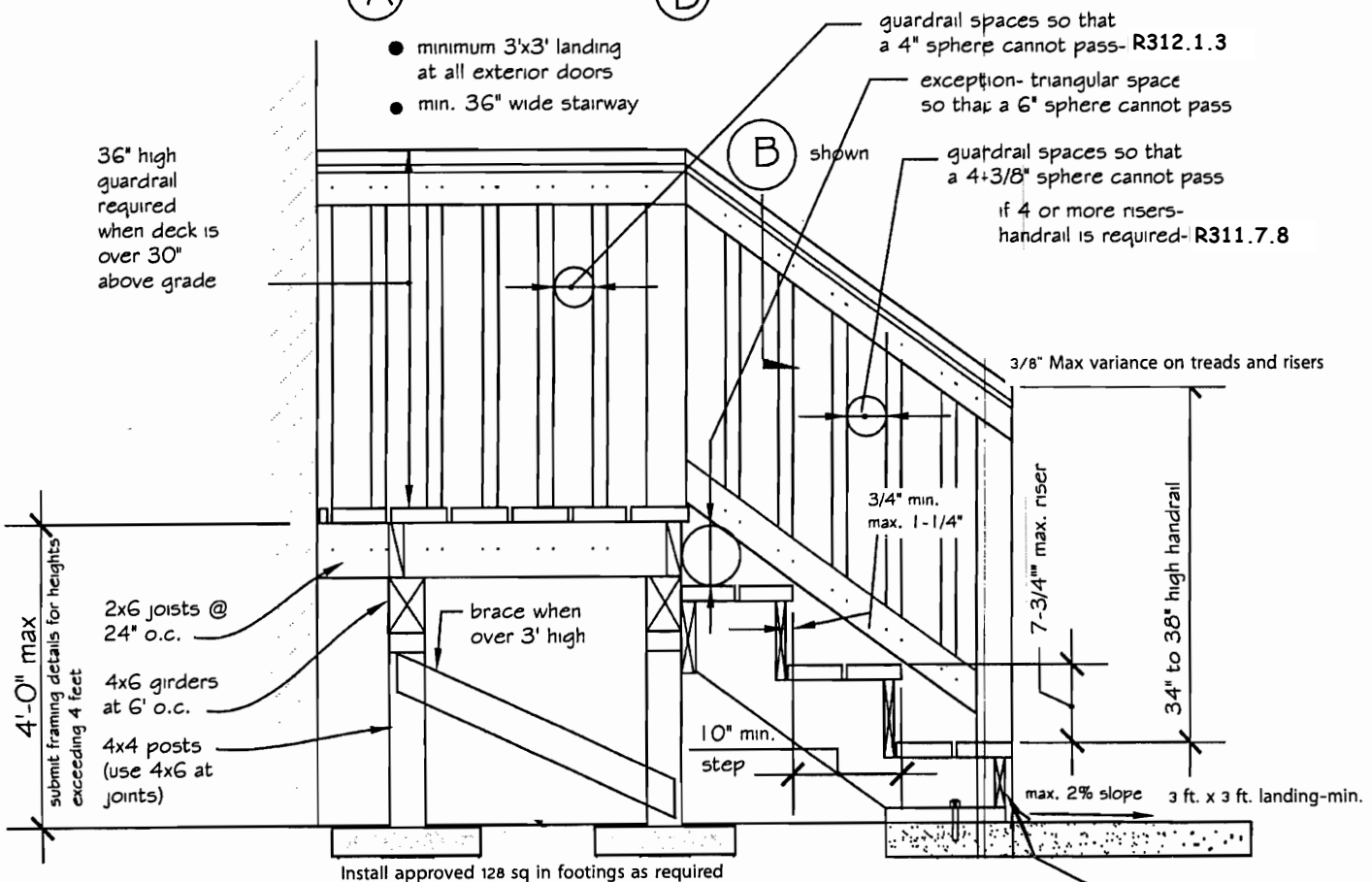

36" high guardrail required when deck is over 30" above grade

4'-0" max submit framing details for heights exceeding 4 feet

2x6 joists @ 24" o.c.
4x6 girders at 6' o.c.
4x4 posts (use 4x6 at joints)

Install approved 128 sq in footings as required

opening between treads does not permit passage of 4" sphere- not limited if total rise is less than 30 inches. R311.7.5.1

All exterior landing and components exposed to the weather must utilize decay-resistant wood such as heartwood of redwood, black locust, cedars or pressure-treated wood in accordance with International Residential Code Section R507.2.1